

Network Standard NS 14.2-2003

Underground Cable Installation Manual

Part II – Technical Requirements



April 2007

For application to Western Power's Distribution Network

Revision A

Revision No.	Issue Date	Description of Amendment	Endorsed By	Approved By
Original	April 2006	Issued on the Web	NA	NA
A	April 2007	Incorporating additional requirements and UDS drawings (DMS#3399230)	Robert Rogerson	Mark Wilshusen

Manual prepared by:

Western Power
ABN 18540492861

Distribution Standards and Policy
Asset Management
85 Prinsep Road
Jandakot WA 6164

Prepared by:	Reviewed by:	Approved by:
Kwok Ng	Robert Rogerson	Mark Wilshusen

© Copyright of Western Power

Any use of this material except in accordance with a written agreement with Western Power is prohibited.

Table of contents

1	PURPOSE.....	1
2	APPLICATION	1
3	GENERAL.....	1
3.1	DEFINITIONS	1
3.2	RELATED INFORMATION.....	4
4	GENERAL UNDERGROUND INSTALLATION REQUIREMENTS.....	5
4.1	GENERAL	5
4.2	SAFETY IN PITS AND TRENCHES	5
4.3	WORKING IN THE PROXIMITY OF OVERHEAD POWER LINES AND INFRASTRUCTURE.....	6
4.4	WORKING IN THE VICINITY OF TRAFFIC.....	6
5	WORK PLANNING.....	6
5.1	RESPONSIBILITIES.....	6
5.2	PLANNING AND RISK ASSESSMENT	6
5.3	NOTIFICATION OF PROPOSED WORKS	7
5.4	PARTICULAR REQUIREMENTS RELATING TO CBD WORK	7
6	SURVEYING AND ‘AS CONSTRUCTED’ RECORDS	7
6.1	SURVEY BENCHMARKS AND DATUM POINTS.....	7
6.2	AS CONSTRUCTED RECORDS.....	8
7	ENVIRONMENTAL AND ABORIGINAL CONSIDERATIONS	8
7.1	ENVIRONMENTAL AND ABORIGINAL ISSUES.....	8
8	CROSSINGS.....	9
8.1	RAILWAY	9
8.1.1	<i>Installation of Ducts and Cables</i>	9
8.1.2	<i>Installation of Markers</i>	9
8.1.3	<i>Installation of power cables under tracks and elsewhere on railway property</i>	10
8.2	PIPES OR CABLES.....	10
8.2.1	<i>Existing Pipes or Cables</i>	10
8.3	GAS MAINS	11
8.3.1	<i>Plastic and Steel Pipes</i>	11
8.3.2	<i>Cast Iron and Old Steel Pipes</i>	11
8.4	COMMUNICATIONS	11
8.5	OTHER ELECTRICITY SERVICES.....	11
8.6	ROAD AND VEHICLE CROSSING.....	12
8.7	HORIZONTAL CABLE CLEARANCE TO OTHER SERVICES AT ROAD CROSSING.....	13
9	CABLE TUNNELS AND SUPPORT SYSTEMS	13
9.1	GENERAL	13
9.2	ACCESS PITS.....	13
9.3	CABLE SUPPORT	13
9.4	TUNNELS.....	14
10	CABLES ON AND OFF ALIGNMENT	14
10.1	CABLE ALIGNMENT	14
10.2	EASEMENTS	14

10.3	GREENFIELD (COMMON TRENCHING)	14
10.4	RETROSPECTIVE	14
11	TRENCHING AND EXCAVATION	15
11.1	GENERAL	15
11.2	EXCEEDING EXTENT OF EXCAVATIONS	15
11.3	USE OF ROCK BREAKING EQUIPMENT	15
11.4	BLASTING	15
11.5	EXCAVATED MATERIAL.....	16
12	DIRECTIONAL DRILLING.....	16
12.1	DRILLED TUNNELS	16
12.2	DIGGING ENTRY AND EXIT PITS.....	17
12.3	PROTECTION OF CABLES IN SPECIAL TERRAIN	17
12.4	DRILLING.....	17
12.5	DRILLING FLUIDS MANAGEMENT PLAN.....	17
13	PLOUGHING	18
13.1	APPLICATION.....	18
14	CABLE LAYING.....	18
14.1	DRUM INSPECTION AND MOUNTING	18
14.2	DRUM POSITIONING.....	19
14.3	PROTECTION OF CABLES FROM DAMAGE.....	19
14.4	CABLE PULLING TENSIONS.....	19
14.5	PULLING SPEED	19
14.6	CABLE BENDING RADII.....	20
14.7	LAYING TO POLES.....	20
14.8	BEDDING AND BACKFILL.....	20
14.9	DEPTH OF COVER OF CABLES.....	20
14.10	CABLE COVER AND MARKER TAPE.....	20
14.11	CABLE SEALING.....	20
15	CONDUITS.....	21
15.1	APPLICATION	21
15.2	BURIED DIRECT.....	21
15.3	ENCASED DUCTS	21
15.4	SEALING.....	21
15.5	COUPLING.....	21
15.6	INSTALLATION OF DUCTS.....	21
15.7	PULLING THROUGH DUCTS.....	22
15.7.1	<i>Armour Pulling</i>	22
15.7.2	<i>Stocking Pulling</i>	22
15.7.3	<i>Nose Pulling</i>	22
15.7.4	<i>Bond Pulling</i>	22
16	REINSTATEMENT	23
16.1	GENERAL	23
16.2	COMPACTION.....	23
16.3	LEVELLING	23
16.4	REMOVAL AND DISPOSAL OF SURPLUS MATERIAL	23
16.5	RESTORATION OF SURFACE	23
17	DAMAGE TO PROPERTY	24

17.1	GENERAL	24
18	PILLARS & PITS	25
18.1	GENERAL	25
APPENDIX A :	CABLE ALIGNMENT AND DEPTH FOR GREENFIELD SITE	A-1
APPENDIX B :	CABLE INSTALLATION DATA	B-1
APPENDIX C :	DIAL BEFORE YOU DIG SERVICE	C-1
APPENDIX D :	DRAWING NO. UDS-6-1P	D-1
APPENDIX E :	DRAWING NO. UDS-6-1	E-1
APPENDIX F :	DRAWING NO. UDS-6-4	F-1

1 Purpose

This manual (UCI manual) formalises the requirements for the safe and efficient installation of all underground cables on the Western Power's distribution system.

The policies, specifications, procedures and guidelines contained in the UCI manual detail the technical requirements to be followed by Accredited Service Providers (ASPs); and also act as a reference to clearly establish defined standards for auditing and assessment work.

2 Application

In general all Western Power (WP) staff and ASPs involved in the installation of high and low voltage distribution cables on the WP network must comply with this manual.

However, for subdivisional work, which is managed by a developer and the subdivision does not require equipment to be installed on public land, some of the items in the UCI manual are not applicable as they are covered by the UDS manual. The Sections and items that are not applicable for subdivisional work that is managed by a developer and does not require equipment installed on public land, are Sections 4, 5, 6, 7, 11 and 13 and special requirements for 'built up areas'. Where the subdivision requires equipment to be installed on public land the public land installation section only is subject to the requirements of the UCI manual. The UCI manual does not apply to the items installed within the subdivided land. Public land is land that at the time of subdivision is freely available for public use, eg existing road reserves, POS, PAWs, etc.

3 General

3.1 Definitions

Accredited Service Provider (ASP)	means a person or an entity who has been accredited through the accreditation scheme of Western Power to undertake any construction work on WP's underground network.
Approved	means having appropriate organisation endorsement in writing for a specific function.
CBD	means central business district.

Cable	means an insulated conductor or two or more such conductors laid together, whether with or without fillings, reinforcements or protective coverings. High voltage cables used by WP are normally un-armoured single core XLPE insulated earthed screen cables, which may be bundled in twisted trefoil for three phase use. The outer jacket is extruded HDPE with typically 2mm thickness. Low voltage cables are usually three core XLPE insulated with a concentric wave wound neutral and an outer HDPE.
Conductor	means a wire, cable or form of metal designed for carrying electric current.
Construction Manager (CM)	means a person who will be WP's site representative and to whom all technical and contractual matters shall be referred.
Contractor	means a person or persons involved in work on or adjacent to assets for which this standard can be applied. This definition may be equally applied to persons who are or are not considered staff of WP.
De-energised	means not connected to any source of electrical supply but not necessarily isolated.
Earthed	means directly electrically connected to the general mass of earth so as to ensure and maintain the effective dissipation of electrical energy.
Energised	means connected to a source of electrical supply.
High voltage	means a nominal voltage exceeding 1,000V ac or exceeding 1,500V dc.
Insulated	means separated from adjoining conducting material by a non-conducting substance which provides resistance to the passage of current, or to disruptive discharges through or over the surface of the substance at the operating voltage, and to mitigate the danger of shock or injurious leakage of current.
Isolated	means disconnected from all possible sources of electricity supply which will prevent unintentional energisation of the apparatus and which is assessed as a suitable step in the process of making safe for access purposes.
Live	means energised or subject to hazardous induced or capacitive voltages.
Live Work	means all work performed on components of electrical apparatus not isolated, proved de-energised and earthed.
Low voltage	means nominal voltage exceeding 50V ac or 120V dc but not exceeding 1000V ac or 1500V dc.

Safe	means not posing an unacceptable risk to life, health or property.
Safety Observer	means a person competent for the task and specifically assigned the duty of observing and warning against unsafe approach to electrical apparatus, or other unsafe conditions.
Shall	is to be interpreted as "mandatory".
Should	is to be interpreted as "advisory or discretionary".
SPURS	Single Phase Underground Rural Supply
Voltage	means a potential difference between conductors or between conductors and earth.
'Western Power's Representative'	(also called ' Liaison Officer ' or ' Construction Manager ') means the officer appointed by WP as it's representative to whom all site, contractual and technical matters are referred.
HDPE	High Density Polyethylene
HV	High Voltage
LV	Low Voltage
PTA	Public Transport Authority
PAW	Public Access Way
POS	Public Open Space
MRWA	MAIN ROADS WA
WAGR	Western Australian Government Railway
WAPC	Western Australian Planning Commission
UDS Manaul	Underground Distribution Schemes Manual
XLPE	Cross-linked Polyethylene

3.2 Related Information

Utility Providers Code of Practice, Main Roads WA

<http://www.mainroads.wa.gov.au/UsingRoads/RoadTrafficInformation/Pages/WorksOnMainRoads.aspx>

Restoration and Reinstatement Specification for Local Governments in Western Australia
Published by the Institute of Public Works Engineering Australia (available from Main Roads WA's web site)

http://www.ipwea.org.au/AM/PrinterTemplate.cfm?Section=Technical_Publications

Western Power Underground Distribution Schemes (UDS) Manual

<http://www.westernpower.com.au/mainContent/connectionsUpgrades/policiesRegulations/technicalDocumentation.html>

Western Power Network Standard NS 07-2003 Testing & Commissioning – Technical Requirements

<http://www.westernpower.com.au/mainContent/connectionsUpgrades/policiesRegulations/technicalDocumentation.html>

Western Power's Environmental Policy

<http://www.westernpower.com.au/mainContent/environment/OurNetworkEnvironment.html>

Information on becoming an Accredited Service Provider (Accredited Contractor) of Western Power

<http://www.westernpower.com.au/mainContent/workingWithPower/industryContractors/BecomingAuthorisedAccreditedContractor.html>

Western Power Switching Operators Manual

Dial Before You Dig Service for lodging an enquiry and requesting a plan

<http://www.dialbeforeyoudig.com.au>

Traffic Management for Works on Roads - Code of Practice, Main Roads WA

<http://www.mainroads.wa.gov.au/UsingRoads/RoadTrafficInformation/Pages/WorksOnMainRoads.aspx>

WorkSafe Code of Practice: Excavation

http://www.commerce.wa.gov.au/WorkSafe/PDF/Codes_of_Practice/index.htm

Occupational Safety and Health Act 1984 and Occupational Safety and Health Regulations 1996.

Explosives and Dangerous Goods Act 1961 and Explosives and Dangerous Goods (Explosives) Regulations 1963.

AS/NZS 3000 – Australian/New Zealand Wiring Rules

AS1742 Manual of uniform traffic control devices, Australian Standards

AS4799-2000 Installation of underground utility services and pipelines within railway boundaries

4 General Underground Installation Requirements

4.1 General

All works must be carried out to meet the requirements of WorkSafe and in compliance with the *Occupational Safety and Health Act 1984* and the *Occupational Safety and Health Regulations 1996*. Operations associated with any task must cease if the safety of workers or the public cannot be assured.

4.2 Safety in Pits and Trenches

All pits and trench work shall comply with WorkSafe requirements. They may include but is not limited to:

- When a pit is to be left open overnight, proper barrier mesh and flashing lights, etc as required must be attached to pickets at least 300mm from the edge of the excavation or the pit must be covered.
- Soil must be piled back from the edge of the pit at least 600mm to conform to WorkSafe regulations.
- Pits or trenches deeper than 1500mm in normal soil may require a ladder for access and require shoring, benching or sloping of the sides of them.
- Pits or trenches may require shoring if less than 1500mm deep and the soil is unstable.
- Undermining walls, foundations, streets or pavements are to be avoided otherwise proper shoring is required.
- All shoring, benching and sloping must be installed to WorkSafe requirements and its *Code of Practice: Excavation*.
- Barriers shall be erected to prevent vehicles inadvertently falling into the excavation.
- Collapse or flooding of trenches.

- Lack of ventilation or suitable lighting.
- Dangerous gases.
- Confined working space.
- High temperatures.
- Traffic hazards

4.3 Working in the Proximity of Overhead Power Lines and Infrastructure

When working in proximity to overhead power lines and equipment, the requirements of WorkSafe must be complied with.

A 10m radius exclusion zone shall always be maintained around all transmission towers and poles.

Prior to carrying out above ground work near WP's power line, the ASP must lodge a "Request to Work Near Underground and Overhead Power lines" with WP and comply with WP's "Applicant Information Pack for Working in the Vicinity of Power lines". The request form and the information pack are available from:

<http://www.westernpower.com.au/mainContent/workingWithPower/WorkingAroundPowerLines/ProtectingWorkersAroundPowerLines.html>

4.4 Working in the Vicinity of Traffic

When working in road reserves or in the vicinity of traffic, traffic management must be carried out to meet the requirements of the "Traffic Management for Works on Roads – Code of Practice" of Main Roads WA.

5 Work Planning

5.1 Responsibilities

The ASP shall obtain information from all utilities about the location of existing services within the proposed area of work. To obtain the underground equipment details, the ASP shall use the Dial Before You Dig Service detailed in [Appendix C](#). Overhead service will be identified visually on site.

The ASP shall also conduct the required tests in accordance with Western Power *Network Standard NS 07-2003 Testing & Commissioning – Technical Requirements*.

5.2 Planning and Risk Assessment

Before commencing work, an on-site team review by all involved parties (including the civil contractor etc) shall be carried out to address hazard management and work practices and shall include but not limited to –

- Identify hazards,

- Assess risks that may result because of the hazard,
- Decide on control measures to prevent, or minimise the level of the risks,
- Implement control measures,
- Particular attention shall be given to, but is not limited to:
 - Traffic management.
 - Refer to Main Roads Dept Code of Practice (on the MRWA Website), and also [Section 5.4](#) for particular requirements in congested traffic areas such as the CBD.
 - Public and worker safety.
 - Potential weather conditions during the work.

5.3 Notification of proposed works

The ASP shall notify MRWA, the local shires and councils and affected public at least five days prior to commencement of work.

5.4 Particular Requirements Relating to CBD Work

Where excavation work is to be carried out, the following factors shall be taken into consideration when pre-planning the job.

This shall be prepared and submitted to the local authority by a person accredited by the MRWA.

All work shall be done to minimise the interruption to local business and allow continue access to businesses for trade.

The hours of work may be restricted depending on the possible noise pollution created from the excavation works.

Some councils will not allow mechanical excavation work in footpaths, e.g. City of Perth. The ASP will need to check with the local Council.

6 Surveying and 'As Constructed' Records

6.1 Survey Benchmarks and Datum Points

There may be official survey benchmarks installed in the project work area. The ASP shall take all necessary precautions to avoid disturbing these markers. Should any markers be disturbed by the ASP, it will be responsible for all costs associated with restoring the benchmarks to their correct position.

6.2 As Constructed Records

Upon completion of all work, the ASP shall provide the CM with the following “As Constructed” records.

- Cable installation record. Where cables are installed using directional drilling, the length and depth of cables shall be recorded.
- Electrical test schedules.
- HV cable joint schedule.
- Materials & equipment schedule.

The “As Constructed” records shall meet the requirements of Section 6.2.4.7 of the *Underground Distribution Schemes Manual* which is available at:

<http://www.westernpower.com.au/mainContent/connectionsUpgrades/policiesRegulations/technicalDocumentation.html>

Standard forms for Electrical Test Schedules, HV Cable Joint Schedules and Materials & Equipment Schedule are available for download from WP’s web site at:

http://www.westernpower.com.au/mainContent/connectionsUpgrades/Professional_Developers/Specialised_Forms.html

7 Environmental and Aboriginal Considerations

7.1 Environmental and Aboriginal Issues

Environmental and Aboriginal impacts must be investigated and managed. Issues may include but not limited to the following:

- Declared Rare Flora and Threatened Ecological Communities (protected by State and Federal Law).
- Biosecurity. Weeds, Pests and Disease Spread, e.g., the spread of Dieback Disease.
- Vegetation Clearing Permit from Department of Environment and Conservation (DEC).
- DEC land entry permits (formerly CALM).
- Protected Wetlands.
- Acid Sulphate Soils. Management plan for the works where they exist.
- Waste Management including Controlled Waste.
- Noise.
- Dust.

- Erosion.
- Incident Response. This includes informing Western Power and relevant departments when unexpected incident or discovery occurs, etc.
- Aboriginal Heritage Sites. Investigate and manage.
- Objects of suspected Aboriginal origin. Policy and Procedure.
- Native Title.

The ASP must comply with the requirements of the *Utility Providers Code of Practice* Section 8.8 and 8.9, and any other relevant legislation.

8 Crossings

8.1 Railway

8.1.1 Installation of Ducts and Cables

“Where site conditions permit, the installation shall be by boring or directional drilling for the portion under the tracks and at least 3m beyond the outer rails or 3m beyond the toe of embankment, whichever is the further. (AS 4799-2000, Clause 3.5.1)”.

In the case of boring, the diameter of the bored hole shall not exceed the outside diameter of the pipe/conduit by more than 50mm. If the diameter of the bored hole exceeds the outside diameter of the pipe/conduit by 50mm or the bored hole needs to be abandoned, the hole shall be backfilled (according to AS 4799-2000, clause 3.9.3) and remedial measures shall be taken to provide support for the railway.

8.1.2 Installation of Markers

Cable markers shall be installed to indicate the location of all underground power cables.

The markers shall be located above or adjacent to the buried cable (AS 4799-2000, Clause 3.10.2):

- At points of entering and leaving the property of the PTA.
- At changes of direction.
- At distance between consecutive markers of the lesser of 200m or line of sight.
- Where specified, at the ends of the under track crossing (the end of the under track crossing is taken as the point 3m beyond the outer rail or toe of the embankment).

The markers shall comply with the following requirements (AS 4799-2000, Clause 3.10.3):

- Stand at least 800mm out of the ground, to the bottom of the marker plate.
- Be of non-combustible material for the marker plates and of at least fire-resistant material for the pole.

- Wording on the markers to be legible, permanent, and formed in a non-combustible medium, or as otherwise approved by the PTA.

The descriptive wording and instructions shown on the markers shall face the railway (AS 4799-2000, Clause 3.10.4).

The wording on the markers shall include the following (AS 4799-2000, Clause 3.10.5):

- The owner's name.
- A warning of the presence of a buried service.
- The nature of the buried service.
- Contact advice in the event of an emergency.

8.1.3 Installation of power cables under tracks and elsewhere on railway property

Power cables passing under the tracks, shall be enclosed in an appropriate 'Category A' system in accordance to AS/NZS 3000:2000. The top of the encasing pipe or conduit shall be at a depth of not less than 2000mm below the top of rail and shall be maintained at this depth for not less 3000mm beyond the outer rails, when measured at right angles to the track (AS 4799-2000, Clause 6.4.2.1), unless otherwise stated in the approved design.

Power cables passing elsewhere on the property of the PTA shall be laid according to AS 4799-2000, Clause 6.4.2.2 and at a depth of not less than 1000mm below ground level, or at the same depth below the level of drain inverts they may cross unless, otherwise stated in the approved design. Where specified by the PTA, the cables shall also be enclosed or covered by protective slabs.

8.2 Pipes or Cables

8.2.1 Existing Pipes or Cables

Whenever a crossing is made of an existing pipe or cable, such pipe or cable shall be securely supported during the progress of the work.

The minimum spaces required between services are contained in the *Utility providers Code of Practice*, summarised as follows:

- Electricity is to pass under gas and water at reticulation crossings.
- The existing cable shall be protected by a split length of heavy duty duct or concrete slabs. If 150 mm clearances cannot be maintained then the cable shall be sleeved with a duct. The length of duct must be at least of 500 mm on either side of the crossing.
- Cover bedding and backfill requirements for water reticulation shall be in accordance with Water Corporation requirements.
- All reticulation shall be laid within plus or minus 100mm of the indicated centre line and secured against movement with initial backfill.

8.3 Gas Mains

Where work is required close to the gas transmission system the ASP must contact the pipeline owner before any work commences (refer to the [Dial Before You Dig Service in Appendix C](#)). When excavating within 20m of a high pressure gas line, the ASP must ensure that a safety observer from the pipeline operator is on site during the work.

Whenever hot work is being carried out in a trench or excavation, which includes a gas main, the ASP must notify the pipeline owner before work commences. Hot work includes welding, naked flames, grinding, and etc.

In some country areas such as Mandurah and Albany a different gas mixture, which is heavier than air, is used. If any work is carried out in a trench adjacent to a gas main in Albany or the Vines Area, the ASP must notify the gas pipeline owner of the work location.

8.3.1 Plastic and Steel Pipes

When carrying out hot work involving a naked flame in the vicinity of an exposed gas pipe, a minimum separation distance of 600mm must be maintained from the gas pipe to the flame. If this is not possible, assistance must be sought from the pipeline owner concerned. A fireproof blanket or barrier must also be placed between the gas pipe and the hot work area.

8.3.2 Cast Iron and Old Steel Pipes

The ASP must call the pipeline owner to site prior to hot work being started to ensure there is no gas is in the trench or surrounding area.

8.4 Communications

Prior to commencement of work, the ASP must contact 'One-Call' 1100 to identify the location of communication services and carry out potholing by soft excavation to identify the actual depth and position of the cables.

The communication's alignment is between 500-1300mm from the verge, and 450mm deep. Whenever a cable crosses is a communications cable, the cable shall be securely supported during the process of the work and the power cable shall go under the communications cable, maintaining a 300mm clearance as per *Utility Providers Code of Practice*.

The space between the power cable and the communications cables shall be maintained when the trench is backfilled.

[Appendix A](#) provides the diagram for the road reserve allocation for utility providers.

8.5 Other Electricity Services

Work on or near underground cables shall be in accordance with the procedures approved by WP. Work shall not commence unless the cable has been identified or located.

The following precautions shall be taken before working on or near cables:

- a) Identify and safeguard against any electrical hazards that are present on the site. These can include, but are not limited to:
 - o live electrical apparatus;
 - o induced voltages;
 - o transfer potentials;
 - o the potential for faults on adjacent cables and joints; and
 - o Capacitive voltages.
- b) Identification of individual existing cables to be worked on shall be carried out using signal generator methods. Using spiking gun methods for HV cables will back the cable identification up. WP will carry out Cable identification.
- c) Identify and safeguard against any physical hazards present on the site. These can include, but are not limited to:
 - o possibility of mechanical damage to existing cables or joints; and
 - o excavating or installing cable.
- d) A worker shall not physically handle a high voltage or low voltage cable, whether sheathed or screened, if its condition is suspect to be damaged, unless the cable is proved to be de-energised.
- e) Subject to (c) above, the ASP shall not physically handle a high voltage cable while it is live, unless authorised by WP's representative.
- f) A high voltage cable shall be isolated, earthed and proved to be de-energised on site prior to commencing work on the cable.
- g) All excavation sites should be examined thoroughly for indications of underground cables and/or conduits, by careful hand excavation.
- h) Cable covers, such as cover slabs or marker tapes, if present, must not be disturbed, and if disturbed reinstated to the appropriate position.
- i) For equipment with earth grids;
 - o particular attention should be paid to areas surrounding pole mounted substations and high voltage switches, as there are often earth grids and bare wires buried in the vicinity of the equipment.
 - o Underground earthing conductors may also have been installed adjacent to certain other poles and structures.
 - o If any unrecorded underground cables, conduits or bare earth wires are exposed, work in the vicinity must cease and WP must be notified immediately.

8.6 Road and Vehicle Crossing

All cables crossing roads and vehicle crossovers shall be installed in cable ducts. Road crossings shall be installed

- perpendicular to property street boundaries, and
- at significant points, e.g., common property boundaries or intersections.

For service cables and streetlight cables, the ducts shall be installed from edge-to-edge of the cable alignment to as practically close to the termination point.

For cables with a large bending radius, road-crossing ducts shall extend a minimum of 1000mm into the roadside verge from the kerb line and as practically close to the termination point. Cable covers shall be installed in the gaps between the end of ducts and the edge of cable alignment.

The above requirements are shown on drawing No. [UDS-6-4 in Appendix F](#).

Where roads and vehicle crossings are already constructed, thrust boring can be used to install the required ducts.

8.7 Horizontal Cable Clearance to other Services at Road Crossing

All cables and ducts crossing roads shall be installed with a minimum horizontal clearance of 150mm from other services.

9 Cable Tunnels and Support Systems

9.1 General

Cables shall be supported on racking with a maximum spacing of 1500mm. Horizontal spacing of cables shall be at least 100mm.

9.2 Access pits

In circumstances where there is a change in route for the cables being installed the design requires the installation of an access pit to be large enough to:

- Allow two people to work comfortably on the cable.
- Install rollers.
- Accommodate for the bending radii of the largest cable available to WP. At present this is 400mm² AI HV XLPE cable.

9.3 Cable Support

The solid cleating support system in which the cleating distance is such that the cable is maintained in a straight line with no sagging may be employed.

Wooden cleats are to be used for paper/lead insulated cables.

When using any of these methods it is necessary to ensure the cable is rigidly held at the cleat position.

Cleats for long vertical runs must be designed to support the weight of the cable. Cleats used on single core cable must be of non-magnetic material, such as wood or aluminium.

Single core cables shall never be surrounded with a steel ring, as this will cause local heating problems.

When applying cleats to cables care must be taken to ensure the correct size cleat is used otherwise damage to the cable may result. A tight cleat may pinch the cable whereas a loose cleat may allow excessive cable movement.

9.4 Tunnels

Where tunnels are to be used the construction and installation requirements will be included on the design drawings.

10 Cables on and off Alignment

10.1 Cable Alignment

Cables shall be installed in Western Power's standard alignment in accordance with the "Utility Providers Code of Practice for Western Australia" and Drawings No. [UDS-6-1 shown in Appendix E](#). Cables can only be installed off the alignment with WP's approval and other affected utilities written agreement.

Other services shall not be installed in the power cable alignment without written permission from Western Power.

10.2 Easements

Where cables, HV and LV, are installed outside the standard alignment or on locations other than road reserves, which includes private property, POS or PAW, they shall be protected by surveyed easements.

Two classifications for underground distribution easements exist and one of these will be selected and documented in the design file.

1. Through the WAPC process easements are applied under Section 167 of the *Planning and Development Act 2005*.
2. Cables requiring protection outside this process will need to register the easement under the *Energy Operators (Power) Act 1979*.

For subdivision developments, developers must comply with the requirements of [UDS Manual](#).

10.3 Greenfield (Common Trenching)

It is the ASP's responsibility to identify all front boundary pegs prior to commencing excavation.

10.4 Retrospective

For retrospective underground areas where the standard cable alignment is not practically available, the cable centre line shall be on the pole and trees alignment of 2.7m from the property line, plus or minus 100mm. The identification of the correct property line is the

responsibility of the ASP and if there is any doubt as to its correct location, the ASP shall obtain directions from the relevant authority.

Where the poles and trees alignment is not available special arrangement will need to be determined.

11 Trenching and Excavation

11.1 General

The ASP shall excavate the trenches to a width sufficient for satisfactory and safe working conditions and shall comply with all relevant Acts, Regulations and requirements of public or statutory authorities.

The ASP shall excavate as necessary to provide the specified minimum cover but so as to avoid damage or loss of support to, obstacles such as pipes, drains, cables and other utilities and services.

The ASP in general shall restore the area to be excavated to its original condition when the excavation is complete. All excavations shall be completed in a timely manner to minimise disruption to all parties.

The ASP shall provide all materials required for the excavation including, but not limited to pumping equipment, shoring, backfill, etc. The equipment must be provided for the entirety of the project.

11.2 Exceeding Extent of Excavations

Excavation in excess of that specified for the laying of the cables shall be made good at the ASP's expense. In the case of excessive excavations, approved sand filling for the bottom of the trenches shall be used.

11.3 Use of rock breaking equipment

Rock shall mean limestone (cap stone), ironstone, igneous rock and concrete etc which occurs in solid masses, or any other material that cannot be practically excavated by a backhoe-type machine or bored, using an approved boring machine.

11.4 Blasting

On occasions blasting operations are undertaken as an aid to excavation in rock, limestone and clay.

Blasting shall not be carried out within the road reserve where other utilities are in close proximity and blasting will affect their equipment.

All explosives handled in the course of blasting operations shall be carried out under the direct supervision of a licensed shot firer in accordance with all relevant Acts and Regulations including the *Explosives and Dangerous Goods Act 1961 and the Explosives and Dangerous Goods (Explosives) Regulations 1963*.

Blasting must be on a very limited scale in built up areas and should only take place after all nearby buildings have been thoroughly inspected, photographed if required and recorded. Adequate warning signs must be displayed and all precautions against flying material taken by the use of pegged or weighted blasting mats or similar aids.

In open country it is possible to make maximum use of explosives. With shallow trenches, up to 2m deep, the ground can often be broken up to its full depth in the one operation. In deeper trenches, benching would have to be undertaken.

It is important that all drilling for blasting be carried out as quickly as possible and extraneous matter is cleared soon after to avoid entering drill holes. It is good practice to temporarily plug drill holes prior to charging. If extraneous material is allowed to enter drill holes the amount of charge possible in each hole will be reduced, thereby diminishing the force of the explosion and fragmentation of the rock.

The ASP shall pay for any damage or injury caused by blasting.

11.5 Excavated material

In built up areas where permitted by the relevant authorities, the ASP shall, where practicable, neatly stack reusable top layers of material such as lawns, pavers, etc on one side of the trench and shall stack the bottom layer of soil separately on the opposite side of the trench.

Some councils require all excavated materials to be removed from site to enable continued pedestrian access without having to walk on the road. Unsuitable soil may have to be disposed of and graded backfill brought in.

No excavated material shall be placed on, or encroach on private property.

In built up areas cover excavated soil with tarpaulin if weather conditions will cause soil to be washed or blown away.

12 Directional Drilling

12.1 Drilled Tunnels

A maximum of two LV cables of 185mm², including streetlight cables can be installed in a common drill tunnel if there will be no tee or service joints along the cables.

One 35mm² HV transformer cable and one LV cable of 185mm² or less can be installed in a common drill tunnel if there will be no tee or service joints along the LV cable.

Multiple high voltage feeder cables (185mm², 240mm² or 400mm²) shall not be combined into a single drill tunnel.

Separate tunnels shall be used between 900mm minimum depth and 1500mm maximum depth. Cable spacing shall meet the requirements of Drawing No. UDS-6-2 in Appendix 22 of the [UDS Manual](#).

12.2 Digging Entry and Exit Pits

An appropriate entry and exit pit are required for directional drilling.

12.3 Protection of Cables in Special Terrain

Where terrain consists of solid rocks or broken rocks, or was a land-fill site, cables installed by directional drilling must be protected by suitable poly-pipes.

12.4 Drilling

During construction continuous monitoring and plotting of the pilot drill and back reamer progress shall be recorded to ensure compliance with the required alignment and depth. The monitoring may be accomplished either be manual plotting based on the location and depth readings provided by the tracking system or by computer-generated track logs fed by this information. The tracking method may be by walkover, wireline, or wireline with a wire surface grid. The tracking system shall provide information on:

- Clock and pitch.
- Alignment and Depth.
- Position (x-y).
- Azimuth - where walkover is not possible.

The bore logs shall show a depth and bore position from a known boundary every 3m along the bore line. These records shall be made available to WP electronically as a permanent record.

To prevent collapse of the borehole, drilling mud or similar rather than just water shall be used for both drilling and back reaming operations.

The pilot hole shall be reamed to provide free sliding of the cable or conduit inside the borehole.

Drilling, back-reaming speeds, and fluid flow shall be set so spoil is removed without putting unacceptable pressure on the surrounding soil (e.g. surface humping).

Pull-back tension shall be set so as not to stretch the cable or conduit beyond it's design limit. See [Appendix B](#) for maximum pulling tension for various cable sizes.

12.5 Drilling Fluids Management Plan

A drilling fluids management shall be completed for directional drilling work.

This shall contain the following:

- Method of slurry containment.
- Method of recycling drilling fluids and spoils if applicable.
- Method of transporting drilling fluids and spoils off site.
- Drilling fluid pressures.

- Measures to contain and clean the affected area for inadvertent return of drilling or hydraulic fluids.
- Measures to adequately clean up of surface seepage of drilling fluids and spoils.

13 Ploughing

13.1 Application

Ploughing of cables at this stage is not an acceptable means of installing underground cables.

14 Cable Laying

14.1 Drum Inspection and Mounting

Upon delivery, the cable drum should be visually inspected for damage, which may have occurred during transport. The manufacturer's seal on the inner and outer cable ends should be examined and the condition of armouring, serving and sheath inspected for mechanical damage, corrosion and leakage of impregnating oil. If the cable is found defective it shall not be installed and the cable shall be returned to the supplier for replacement.

During installation the cable should be carefully examined for any sign of damage as it leaves the drum. This is particularly important on the outer layers, where drum batten nails can cause damage.

If it is necessary to roll the cable drum, it should be rolled in the direction indicated by the arrow on the drum.

The drum should be mounted on jacks, cable trailer or cable stands such that the cable is preferably pulled from the top and always in the direction opposite to that indicated by the arrow. Lighter cables may be laid by mounting the cable drum on its side on a truck-mounted turntable and laying the cable directly into the trench. When pulling from large drums, i.e. over 2m in diameter, the cable should be supported to prevent stressing the cable, from the drum to the trench on a suitable ramp.

Alternatively, cables can be rolled directly into a trench from the drum mounted on an excavator moving along the trench.

To limit the chance of damage to the cable prior to removing the cable drum battens, a check should be done to ensure that the drum-spindle is level and permits even rotation of the drum.

During pulling there is a tendency for cable slack to accumulate on the drum, slack shall be avoided and one possible method to achieve this is to limit drum rotation by using plank brake shoes against one or both flanges of the drum. If the inner end of the cable on the drum, referred to as the "Z" end, protrudes through the side of the drum, then it should be watched during pulling to ensure it is not damaged. It is advisable to tie a rope to the Z end, and pull through any slack cable that appears. Pulling through Z end prevents buckling, and possible damage to the inner coils on the drum.

14.2 Drum Positioning

Cable drums shall be positioned in line with the direction of cable pull.

14.3 Protection of Cables from Damage

Cables being drawn into place shall be kept clear of abrasive surfaces by suitable means, e.g. rollers, cable tiles, etc., to prevent any damage to the cable sheath. The cable must be placed in the trench without sustaining abrasion damage, and without allowing rocks etc., to fall into the trench.

If the cable is hand flaked directly from cable drum or coil into final position or other method that does not drag the cable over ground cable rollers are not required.

On long cable runs where a cable changes direction, both horizontal and vertical, rollers shall be used to ensure a smooth pull and avoid damage to the cable. Cables, which are pulled into position by a winch, must use suitable cable stockings and swivels to prevent damage.

When laying cable by directional drilling, it is essential the cable is not dragged over ground outside the drill hole or prepared trench, since abrasion is likely to damage the outer jacket and cause sheath faults.

14.4 Cable Pulling Tensions

The tensions of the pull shall not exceed that specified by the manufacturers for the particular type and size of cable being pulled and shall be smoothly and continuously applied.

When stocking grips are used to install un-armoured cables, the maximum recommended pulling tensions are shown in [Appendix B](#).

The trench or duct line should be set out so that any necessary deviations from a straight line occur over the largest possible radius. When pulling cable into duct lines incorporating bends lower maximum pulling tensions may be necessary to avoid the wire pulling rope cutting into the side of the duct.

Any winch used to pull cables shall have either a facility to automatically limit the pulling tension applied to a cable or a continuous reading dynamometer incorporated in the pulling arrangement to enable the actual pulling tension to be monitored.

Cable pulling pits are required at each significant change in cable route direction. The pits will be indicated on the design drawing.

14.5 Pulling Speed

To avoid damage due to overruns, the cable should be pulled just fast enough to keep the drum rotating smoothly.

Higher speeds are possible when pulling small cables into straight trenches or ducts with good conditions at the feeding and pulling ends. Drums with long lengths of cable, however, should not be rotated rapidly as overrun can cause cable damage if pulling is slowed or stopped suddenly.

14.6 Cable bending Radii

The permissible bending radii of all cables are given in [Appendix B](#). No twists, knots or kinks are permitted.

Where a 3x1 core HV cable is to be laid to transformers or switchgear, the three twisted cores can be separated into three individual cores to reduce the minimum bending radius required. The bending radii are given in [Appendix B](#).

14.7 Laying to Poles

Where cables are to be laid to termination poles, a complete loop shall be buried on the property boundary side of the pole to allow sufficient slack for future replacement of the pole or failed cable termination. The loop shall have a radius not less than the maximum, being the radius of the cable. The cable shall be protected by cable slabbing and marker tape around the loop.

14.8 Bedding and Backfill

Cable shall be bedded in clean sand, which shall extend 100 mm around the cable.

Backfilling shall comply with the published "*Subdivision Design Guideline – Number 4, Bedding Sand and Backfill Around Cables and General Backfill for Cable Trenches – materials Selection Guidelines.*" It can be found at:

http://www.westernpower.com.au/mainContent/connectionsUpgrades/Professional_Developers/Technical_Documentation.html

All cables shall be firmly and uniformly bedded on sand free from rocks or other hard formation. The cable shall be surrounded with a thickness of sand prior to backfilling, bottom by 150mm and two sides by 100mm, top by 300mm as shown in drawing [UDS-6-1 in Appendix E](#). The upper 300mm of the backfill shall also meet the local government authority's requirements.

14.9 Depth of Cover of Cables

The depth of cover of cables shall not be less than 750mm. However, the depth of cover of cables in nominal cable alignment shall be increased as required so that cables joints will have the necessary depth of cover.

14.10 Cable Cover and Marker Tape

Cable covers, if required, and PVC marker tape shall be laid at the required levels, as shown in drawing [UDS-6-1 in Appendix E](#). The cable covers shall comply with the requirements of clauses 3.11.3.3 of *AS/NZS 3000:2000*. Where more than one cable is installed, the PVC marker tape or cable cover must be wide enough to fully cover the cables, otherwise additional marker tapes and covers shall be installed.

14.11 Cable Sealing

On completion of the pull, any pulling eyes fitted should be removed and the cable resealed unless about to do termination. Resealing is required to repair any damage that may have occurred to the cable seal through pulling.

15 Conduits

15.1 Application

Conduits and ducts complying with Australian Standard AS2053 shall be used to protect cables installed in the following situations:

- Cables installed outside the 0-500mm standard alignment.
- Cables installed in easement.
- Exist cables of a distribution substation that is set back from road or property boundary.
- Cables near to retaining walls.
- Cables crossing roads.
- Cables crossing water course and drains.
- Cables crossing high pressure gas pipelines.
- Cables crossing under railway.
- Cables within bridge crossings.

15.2 Buried direct

When buried direct outside the 0-500mm standard alignment is approved by WP, ducts are not required. The cables must be laid in open trench, backfilled with clean sand in accordance with Section 14.9 and protected by cable slabs as shown on drawing No. [UDS-6-1 in Appendix E](#).

15.3 Encased ducts

In some locations PVC ducts may be encased in concrete ducts or concrete. Cables shall never be installed in concrete ducts.

15.4 Sealing

All spare conduits must be sealed against the ingress of water and any foreign material that may hinder in the pulling of future cables.

Sealing of the conduits must be carried out to prevent blockage, and flooding of cable pits and basement-type substations and switchroom.

15.5 Coupling

PVC cement shall be used to join ducts to prevent entry of water and foreign matter into the conduit.

15.6 Installation of Ducts

All ducts shall have a minimum cover of 750mm to the top of the duct and no ducts shall be installed with more than 1100mm cover except railway crossing in Section 8.3.1. Where cables in a trench are all installed in ducts, local soil excavated from the trench can be used for bedding and backfill, provided it is free of organic matter and rocks of 75mm diameter or larger.

Ducts are to be laid in horizontal formation, up to four in parallel, and thereafter in tier formation.

Road crossing ducts shall be installed in accordance with [Section 8.6 –Road and Vehicle Crossing](#).

All ducts shall be plugged with suitable end caps. Draw wires shall be provided in spare ducts. When the ducts are installed prior to the main cable trenching, marker tape shall be installed 300mm above the duct, and brought out to ground level at each end with a marker peg at one end. Marker pegs are not required for greenfield subdivision developments.

The most economic method shall be used to install conduits across roads. Subject to cost, boring is preferred for all single or double conduit crossings, where conduits of 100mm size or larger are to be installed. For locations where more than two ducts are to be installed together, open excavation methods may be used for crossing roads.

15.7 Pulling through Ducts

Care shall be taken to avoid damaging the outer sheath of the cable where it enters and leaves the duct. Single core bundled XLPE high voltage cables are particularly susceptible due to their uneven shape and thin outer sheath. A suitable lubricant should be used to reduce the friction between the cable and the duct. A tapered or belled entry shall be used at the entry end of ducts during pulling to prevent damage to cable.

There are numerous methods by which the cable can be pulled into the final installed position. Generally, the most economical methods employ power winches. If considering only those pulling methods using mechanical winches, then there are four distinct methods:

15.7.1 Armour Pulling

This system uses the actual armour wires of the cable as the pulling medium. The armour wires, left extended past the end of the cable, are formed into a pulling eye and the winch rope attached to it. This method is not applicable to XLPE cables.

15.7.2 Stocking Pulling

Cable pulling using a cable stocking is probably the most common form of installation for cable up to and including 33kV. The cable stocking is slipped on to the end of the cable and the winch rope attached. On applying tension the stocking shrinks diametrically until a firm grip is obtained. Care must be taken when using this method to ensure that pulling tension is not excessive, otherwise sheath stretch may result.

15.7.3 Nose Pulling

The strength of the cable sheath limits the length and size of the cable that can be pulled by stocking pulling. For long and large cross section cables, pulling-eyes can be fixed directly to cable conductors for pulling the cable.

15.7.4 Bond Pulling

When pulling tensions exceed the tension limit of the cable, straight end pulls may have to be replaced by bond pulls. The cable is lashed to a steel wire rope, which takes all the strain of the pulling.

16 Reinstatement

16.1 General

In built up areas the ASP shall restore the excavated land to its original condition. Backfilling and reinstatement of road verges and vehicle crossings as necessary shall be completed within three working days from the time the cables are laid and jointed.

Road reserves and all work sites shall be levelled and left clean and tidy. Debris, trees, stumps and excess soil dug from the excavation shall be removed from site when finished trench backfilling

All materials, stakes, plant and equipment used during installation shall be removed by the ASP and all work sites left in a safe condition.

The initial backfill over the bedded cables shall be carried out in accordance with [Section 14.8 – Bedding and Backfill](#).

Trenches shall be subsequently backfilled, reinstated compacted to their original level and/or in accordance with that required for footpaths by the Local Government Act 1960.

16.2 Compaction

Spoil or other approved filling shall be carefully placed in the trench. Stones, rocks and paving material shall be removed. The whole of this backfilling shall be carried out so as to avoid future subsidence.

In all other cases the backfilled material will be compacted to the same density as the surrounding soil.

16.3 Levelling

The surface shall be left in such a condition as not to constitute a hazard and shall be the same as the original unexcavated land.

16.4 Removal and disposal of surplus material

The ASP shall be responsible for removal and disposal of all surplus spoil from the Site.

Any pipe or cable off-cuts shall not be buried in the trench.

All unusable cable lengths and unsuitable material supplied by WP shall be reconciled and returned WP's stores.

16.5 Restoration of surface

In all areas except greenfield subdivision developments, upon completion of any operation affecting pavements or constructed surfaces, the ASP shall restore the pavements or constructed surfaces in accordance with the *Restoration and Reinstatement Specification for Local Governments in Western Australia* Published by the Institute of Public Works Engineering Australia, which is available on the Institute of Public Works Engineering Australia web site:

http://www.ipwea.org.au/AM/PrinterTemplate.cfm?Section=Technical_Publications

Restoration of surface includes restoration of footpath of all type of materials, e.g. bitumen, brick paving, liquid limestones, etc.

If pavements or any constructed portions of any road reserve are broken to any particular extent without prior approval of WP's Representative no payment will be made to the ASP and the ASP will be charged with the restoration costs incurred by Western Power.

Where cement footpath slabs have been removed to allow cable trench excavation, they will be replaced and reinstated in accordance with the Local Council's requirements, unless otherwise directed by the WP's representative.

17 Damage to Property

17.1 General

In built up areas property or services damaged by the ASP shall be repaired or replaced at the ASP's cost (or at the cost of developers in the case of subdivision development) as soon as possible after making safe.

Fences around areas holding livestock shall be secured at all times and if damaged during construction shall be repaired or made safe immediately to prevent the stock from straying.

The ASP shall be responsible for the cost of repairing any damage to reticulation systems and underground services that are disturbed or damaged in the performance of the services and for restoring them to working order.

Trees planted in the road verge shall be protected as far as possible. Tree limbs interfering with the construction shall be removed appropriately by pruning and sealing and the trees left in a reasonable condition.

The ASP is required to inspect any structures located along the cable trench route and shall make arrangements to protect these structures if there is a possibility of damage or hazards occurring.

The ASP shall notify the WP's representative forthwith in all cases of such damage or hazards occurring.

18 Pillars & Pits

18.1 General

Service pillars must be located within the lot boundaries at the corner as shown on drawing No. [UDS-6-1P in Appendix D](#).

Pits shall only be used where it is impractical to install a pillar, such as on a traffic island or beside a narrow driveway.

Service pit installation

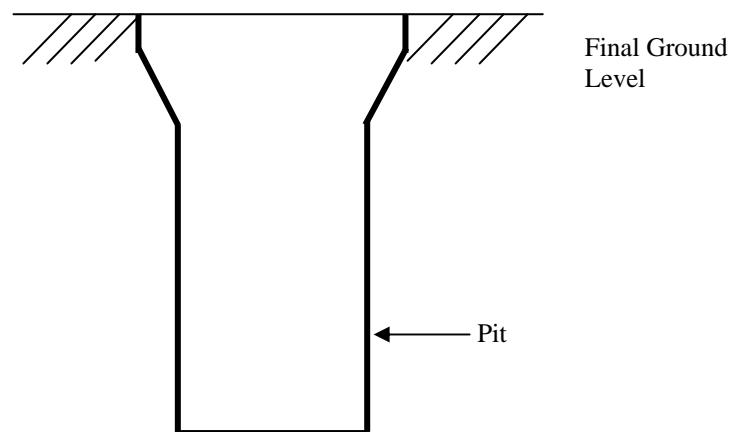

- 1 Locate the service pit in the preferred location taking into account:
 - Available space
 - Trafficable areas
 - Proximity of other utility pits
- 2 Determine **final** ground level
- 3 Install pit so that top of pit is flush with final ground level
- 4 Install utility service cable conduit
- 5 Leave ground open for installation of customer service/s and street lighting cable conduits
- 6 Partly backfill and compact soil around pit
- 7 Install insulating barrier
- 8 Fit pit lid and keyhole plug
- 9 When customer service/s and street lighting cable conduits have been installed complete backfilling and soil compaction around pit

Where there is a change in level between the service tee and the pillar, the cable shall be protected in conduit where it traverses the slope.

Appendix A: Cable alignment and depth for Greenfield Site

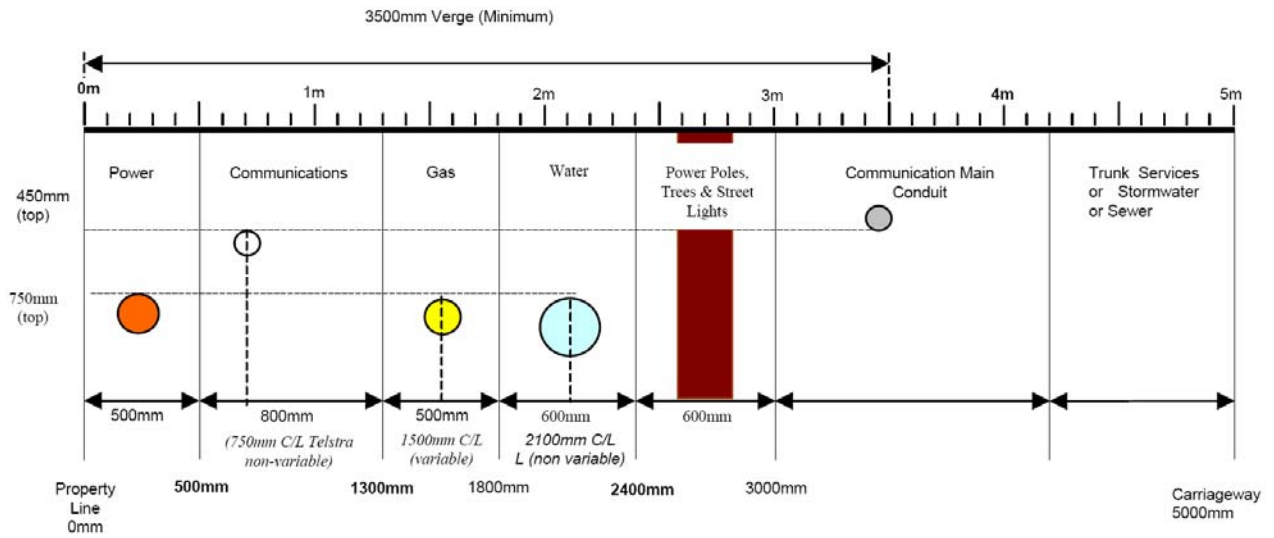

Note: The minimum depth of cover of cables is 750mm. However, the depth of cover of cables in nominal cable alignment shall be increased as required so that cables joints will have the necessary depth of cover.

Cable Alignment and Depth (Greenfield Developments)

Appendix B: Cable Installation Data

Type of Cable	Voltage (kV)	No of Cores	Cable Size (mm ²)	Conductor Material	Reel Length (m)	Nominal Overall Cable Diameter (mm)	Maximum Pulling Tension (per core for HV) (kN)	Minimum Bending Radii (Bundle/One Cable)	
								Installing (mm)	Installed (mm)
Transformer Cable	33	3x1	50	A1	250	82	1.47	1000/480	850/410
HV Feeder Cable	33	3x1	95	A1	250	94	4.74	2330/1110	1400/670
HV Feeder Cable	33	3x1	185	A1	250	102	5.20	2596/1185	1557/715
Transformer Cable	12.7/22	3x1	35	A1	250	68	3.48	1710/790	1025/475
HV Feeder Cable	12.7/22	3x1	185	A1	250	93	5.40	1700/780	1400/520
HV Feeder Cable	12.7/22	3x1	240	Cu	250	98	7.84	2465/1125	1480/675
HV Feeder Cable	12.7/22	3x1	400	Al	220	109	7.32	1635/1200	1090/720
LV Feeder Cable	0.6/1	1x3	120	A1	250	39	5.20	700	470
LV Feeder Cable	0.6/1	1x3	185	A1	250	47	7.70	850	570
LV Feeder Cable	0.6/1	1x3	240	A1	250	54	10.00	970	650
Service	0.6/1	1x3	25	Cu	250	26	3.10	160	105
Street Lighting	0.6/1	1	10	Cu	1000	11	0.70	70	48
Street Lighting	0.6/1	1	16	Cu	1000	14	1.10	80	55

Note: The ASP shall obtain and verify the cable installation data from the cable manufacturer.

CABLE INSTALLATION DATA

Appendix C: Dial Before You Dig Service

General

Dial Before You Dig Service (sometimes referred as One Call System) provides a single statewide point of contact between excavators and major utilities which own buried pipes and cables, as well as the owners of other buried services.

This free service makes it safer and easier for people undertaking excavation activities.

The following information will help you make the best use of the Dial Before Your Dig service.

Simply dial 1100 at least two working days in advance of your intention to excavate. A number of questions will be asked.

Enquiries may also be lodged by facsimile 1300 652 077 or Internet <http://www.dialbeforeyoudig.com.au>.

This information is needed to clearly identify the precise location where excavation is proposed, the potential impact of the activity, a contact person and their address for issuing of the services information, and whether or not on-site assistance is required.

What do I need to know when dialing 1100?

When calling 1100 be ready to provide the operator with:

- Your name and address
- name of company (if applicable)
- contact telephone number
- facsimile number for return information
- contact on site
- site address
- commencement date of the proposed work
- type of work being carried out

Within two days you will receive plans of relevant underground services.

If you have not received information from Dial Before You Dig after two working days from the date of your request, contact Dial Before You Dig direct on 08 9424 8117 or 08 9424 8118 during office hours (8.00 am - 5.00 pm weekdays).

Note: No work is to commence until all relevant information has been received.

If you have already received information from Dial Before You Dig, further data and other information can be obtained by telephoning the contacts listed on the cover sheet provided.

Be aware that not all underground service owners are members of Dial Before You Dig. Refer to relevant road authority (Main Roads WA or Local Government).

Further information

For further information on Dial Before You Dig, telephone (08) 9424 8117 or (08) 9424 8118 during office hours.

Further Telstra information can be obtained by telephoning 1800 806 246.

Appendix D: Drawing No. UDS-6-1P

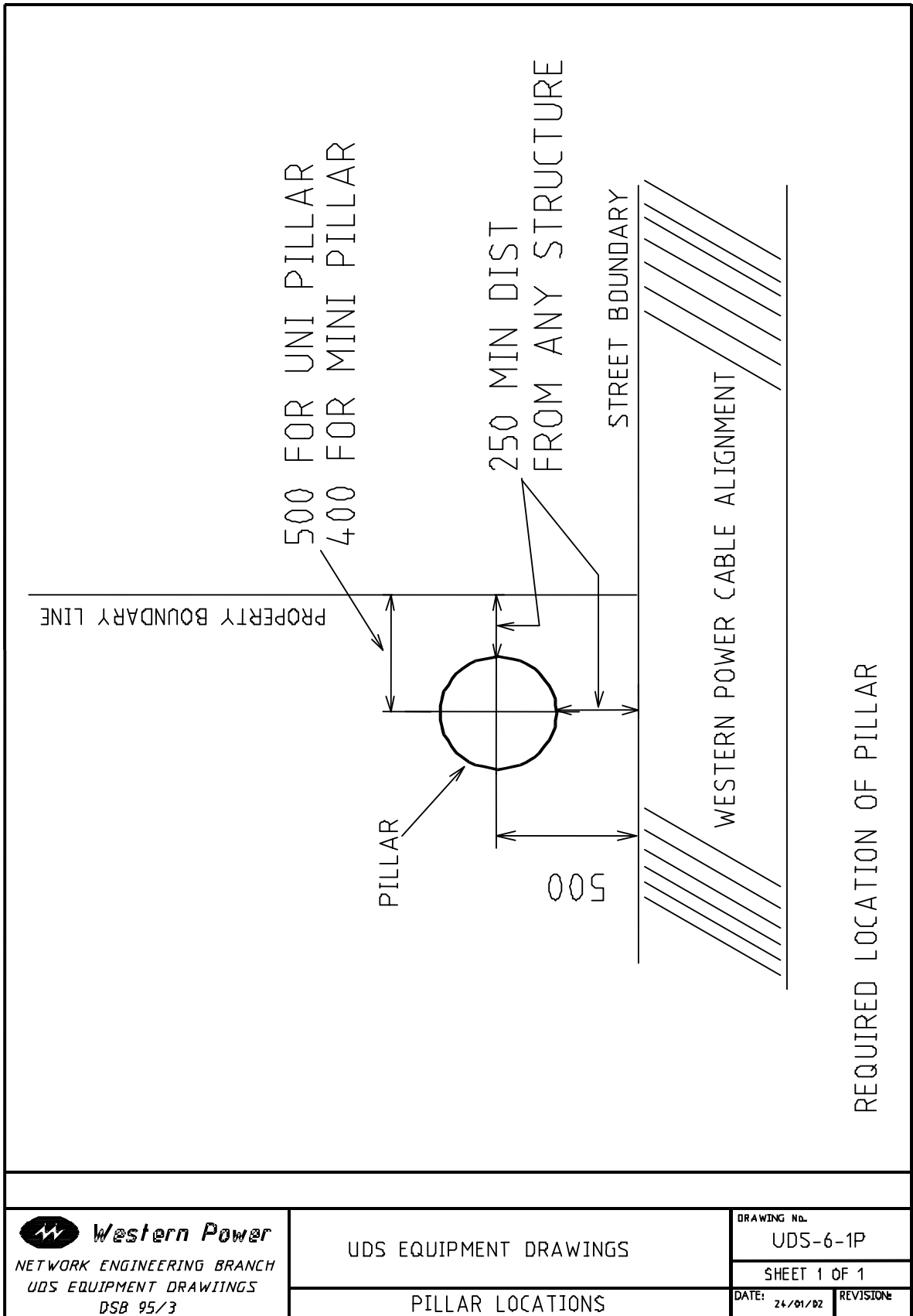

Appendix E: Drawing No. UDS-6-1

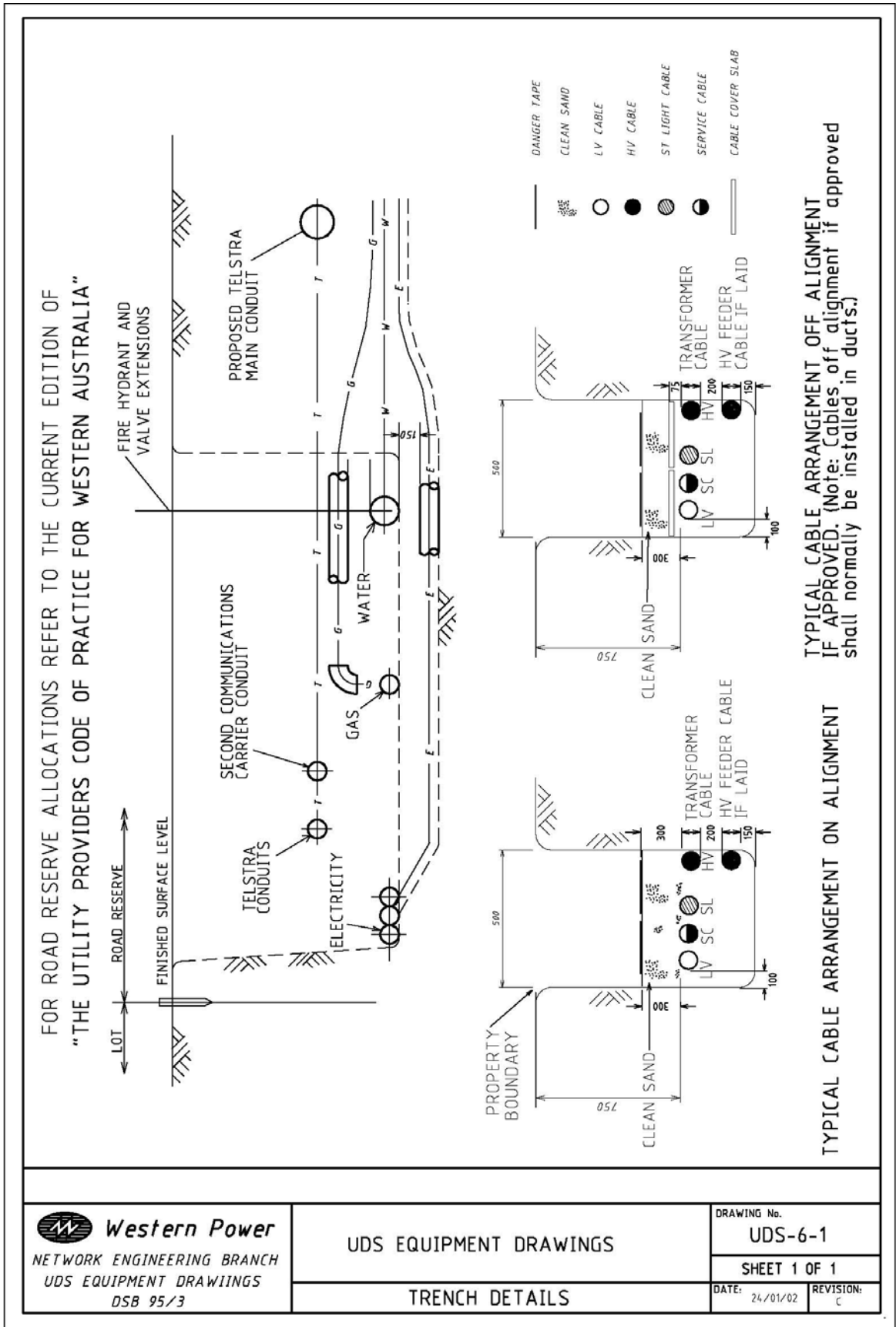

Western Power
NETWORK ENGINEERING BRANCH
UDS EQUIPMENT DRAWINGS
DSB 95/3

UDS EQUIPMENT DRAWINGS

TRENCH DETAILS

DRAWING No.
UDS-6-1

SHEET 1 OF 1

DATE: 24/01/02 REVISION: C

Appendix F: Drawing No. UDS-6-4

